

END-OF-STROKE PROXIMITY SENSOR, THREADED MOUNT

This type of switch signals the end-of stroke of the cylinder by sensing the ferrous cushion bosses on each side of the piston. The switch contains an internal magnet that operates a conventional single pole, double throw, form C switch. These O.D. threaded switches are mounted through the cylinder heads on approximately the same axial centerline as the ports.

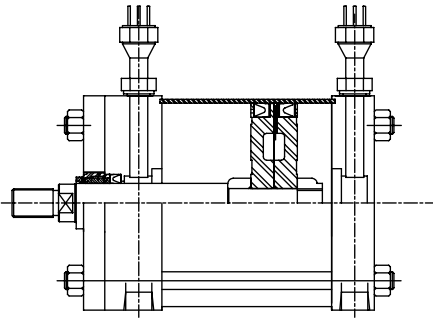

Contact Rating: 2 Amp @ 240 VAC
3 Amp @ 24 VDC
Response Time: 0.008 seconds
Repeatability: 0.002" of set operating point under identical conditions
Approvals: UL, CSA, BASEEFA and SA

LINEAR DISPLACEMENT TRANSDUCER

Linear position sensing provides a non-contact displacement transducer that offers a high degree of accuracy. This type of unit is mounted axially through the cylinder closed head with the probe extending into a clearance in the piston rod.

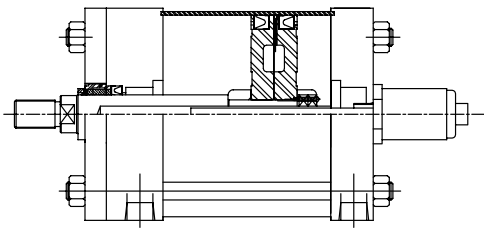

Linearity: $\pm 0.02\%$ or better
Repeatability: $\pm 0.001\%$ or 0.0001" of full stroke, whichever is greater
Control Interface: Digital or Analog output
Approvals: UL and CE

Various models and protocols are available.

SERVO-POSITIONING SELF-LUBRICATING AIR CYLINDER

The Lehigh Positioning Cylinder is an air cylinder directly coupled to a force-balance, servo-type positioner. This combination provides a means of controlling the stroke of the piston rod to any desired length up to full stroke. The stroke control, by a remote pressure transmitter, is repeatable and infinitely variable.

This air cylinder assembly provides a precise method for creating and controlling forces by the plant operator or process transmitter located at some distance from the output device. It can develop long power strokes and may be controlled to any point in its travel.

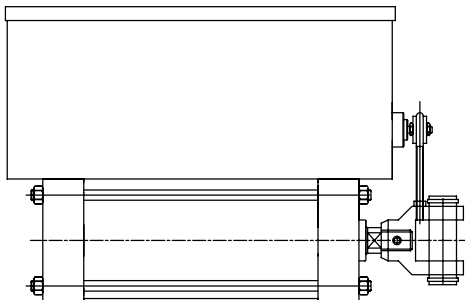

Applications include:

- ✓ Control of damper and louvre openings
- ✓ Regulating gates, shutters and doors
- ✓ Lifting loads to exact position
- ✓ Positioning slides on automated equipment
- ✓ Modulating valves

Various models and protocols are available.

*Ordering: Contact Lehigh sales and engineering for application assistance to define ordering information.
Specifications are subject to change without notice*

POSITION SENSING CYLINDERS

SERVO-POSITIONING (Cont.)



SERVO-POSITIONING SELF-LUBRICATING AIR CYLINDER (Cont.)

The Lehigh Positioning Cylinder features Lehigh's Miracalube® self-lubrication system (see page 4). The cylinder is rated for dry air and will give quick start-up operation, whether frequently used or not. It operates on pneumatic service from 25 to 150 PSI and seal temperatures to 165°F. The cylinders are from 2" to 8" diameter bore and are supplied with NFPA standard mounting styles.

The Positioning Cylinder operates on the same principles as the typical valve positioner widely used in the process industries. A precisely regulated air pressure known as "instrument air" is piped to the Positioner. The pressure transmitter for this air supply is actually a precision regulator with an adjustable output of 3 to 15 PSI.

(This device is not part of the Positioning Cylinder.) In general, when the Positioning Cylinder receives a change in signal pressure it diverts the supply air

precision regulator with an adjustable output of 3 to 15 PSI. (This device is not part of the Positioning Cylinder to one side or the other of the cylinder piston, thereby responding in stroke length proportional to the change in signal pressure.

Specifically, the instrument air pressurizes a diaphragm holding the inner end of a long spring. When the instrument air pressure changes, the diaphragm moves slightly, thus changing the air flow through a small internal nozzle. This change causes an internal pilot valve to shift, thus introducing supply air to one side of the main cylinder piston. The differential pressure moves the piston rod which extends the spring, pulling the diaphragm back into its neutral position. The unbalance of the valve is nullified, the supply air is equalized on both sides of the piston and the system comes to rest.

POSITIONER ASSEMBLY DIMENSIONS

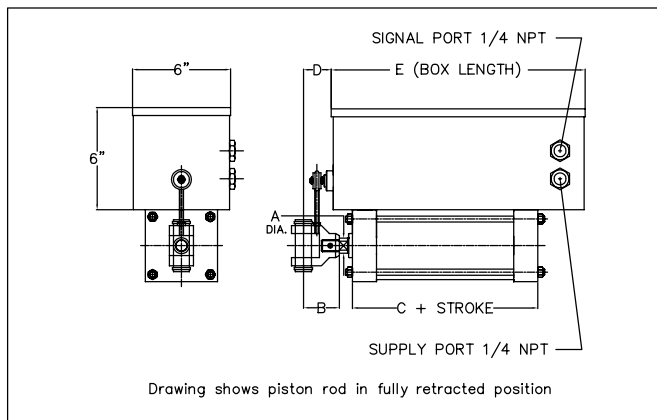

JHD	BORE SIZE	A	B	C	D
20	2	5/8	1 1/2	4 + STROKE	2 1/4
25	2 1/2	5/8	1 1/2	4 1/8 + STROKE	2 1/4
32	3 1/4	1	2 3/8	4 7/8 + STROKE	3 1/4
40	4	1	2 3/8	4 7/8 + STROKE	3 1/4
50	5	1	2 3/8	5 1/8 + STROKE	3 1/4
60	6	1 3/8	3 1/8	5 3/4 + STROKE	4 1/8
80	8	1 3/8	3 1/8	5 7/8 + STROKE	4 1/8

JHD	E (BOX LENGTH)				
	TO 3" STROKE	OVER 3" TO 6" STROKE	OVER 6" TO 9" STROKE	OVER 9" TO 15" STROKE	OVER 15" TO 18" STROKE
20	12	18	24	30	36
25	12	18	24	30	36
32	12	18	24	30	36
40	12	18	24	30	36
50	12	18	24	30	36
60	12	18	24	30	36
80	12	18	24	30	36

APPLICATION AND NOTES

1. Specify whether piston rod is to extend or retract as the transmitter pressure is increased.
2. Supply with clean air free of oil and moisture not exceeding 150PSI.
3. Cylinder assembly is Lehigh JHD series heavy duty air cylinder with the unique Miracalube® self-lubrication system. Refer to the NFPA standard mounting styles on pages 14-28 for cylinder dimensions on bore sizes from 2" to 8".
4. Cylinder bore sizes are from 2" to 8" diameter. Strokes are to 18" or more. Because of the forces required in balancing the piston, bore sizes should be sized well above the theoretical rating.
5. Positioner assembly is a commercial unit adapted by Lehigh to this application. The usual input range is from 3 to 15 PSI or 4-20 mA, but other instrument ranges can be designed for. Typical configurations supplied by Lehigh in this design have included Moore, Accord and Fisher positioner controls.